



UNIVERSITY OF CAMBRIDGE INTERNATIONAL EXAMINATIONS
General Certificate of Education Ordinary Level

www.PapaCambridge.com

COMBINED SCIENCE

5129/11

Paper 1 Multiple Choice

October/November 2012

1 hour

Additional Materials: Multiple Choice Answer Sheet
 Soft clean eraser
 Soft pencil (type B or HB is recommended)

READ THESE INSTRUCTIONS FIRST

Write in soft pencil.

Do not use staples, paper clips, highlighters, glue or correction fluid.

Write your name, Centre number and candidate number on the Answer Sheet in the spaces provided unless this has been done for you.

There are **forty** questions on this paper. Answer **all** questions. For each question there are four possible answers **A, B, C** and **D**.

Choose the **one** you consider correct and record your choice in **soft pencil** on the separate Answer Sheet.

Read the instructions on the Answer Sheet very carefully.

Each correct answer will score one mark. A mark will not be deducted for a wrong answer.

Any rough working should be done in this booklet.

A copy of the Periodic Table is printed on page 20.

This document consists of **16** printed pages.



* 8 2 4 7 9 5 3 9 4 5 *

- 1 The width of a wooden block is measured using vernier calipers.

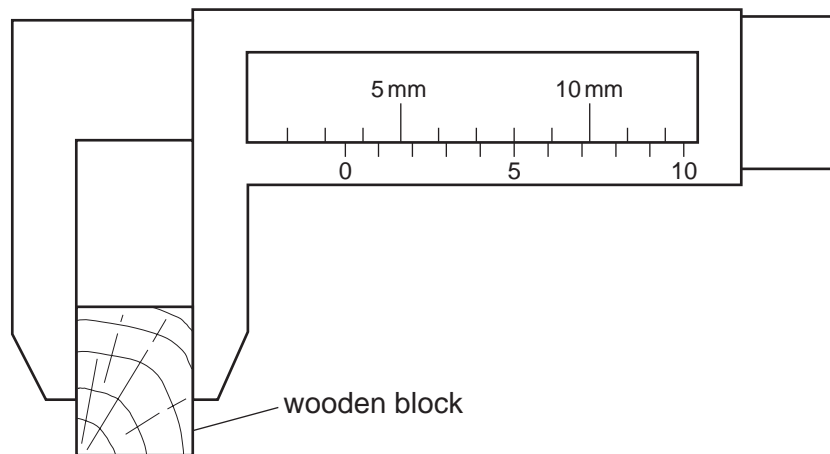

What is the width of the block?

- A** 3.5 mm **B** 5.3 mm **C** 8.0 mm **D** 8.5 mm
- 2 The velocity of a moving car is constant during part of a journey.
What is the acceleration during this time?
- A** decreasing all the time
B increasing all the time
C increasing, then decreasing to zero
D zero all the time
- 3 What describes the density of a material?
- A** the amount of matter in the material
B the mass per unit volume of the material
C the pull of gravity on the material
D the volume per unit mass of the material

- 4 The diagram shows a boy of weight 500 N sitting on a see-saw. He sits 2.0 m from the

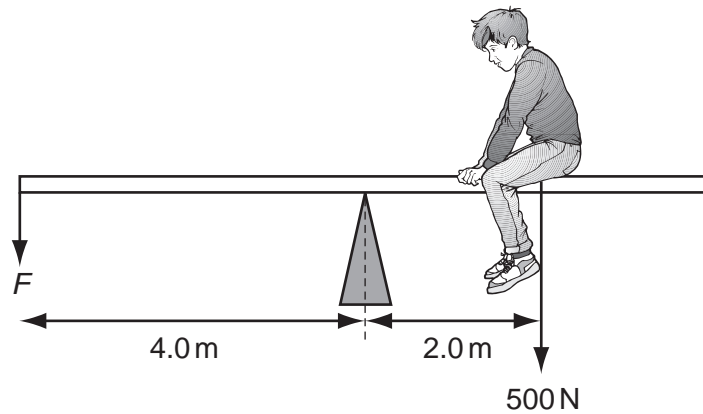

What is the force F needed to balance the see-saw?

- A** 250 N **B** 750 N **C** 1000 N **D** 3000 N
- 5 A cell will deliver 3000 J of energy to a 2 W electric motor before the cell is exhausted.
How long will the motor run?
- A** 25 minutes
B 100 minutes
C 1500 minutes
D 6000 minutes
- 6 How much work is done in lifting a mass of 90 g vertically through a distance of 10 m?
(gravitational field strength is 10 N/kg.)
- A** 0.9 J **B** 9 J **C** 90 J **D** 900 J

- 7 The diagram shows a radiator being used to heat a room.

Which arrow shows the movement of the air around the room?

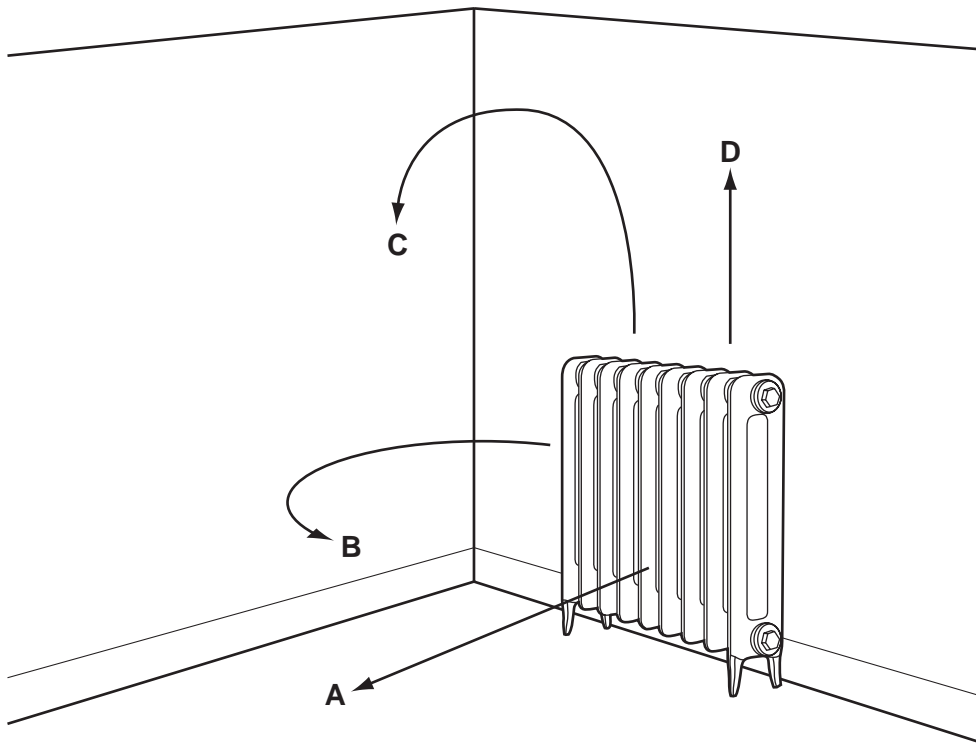

- 8 The diagram shows the cross-section of a water wave.

Which is the amplitude of the wave?

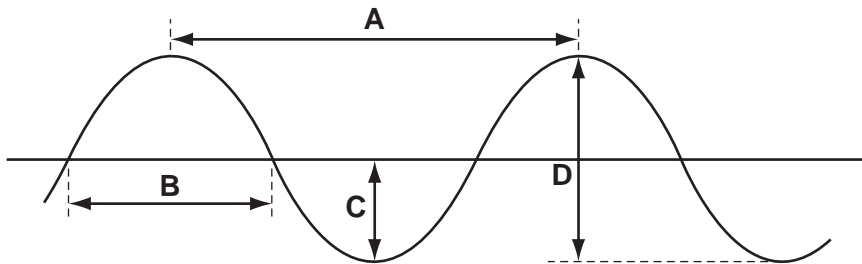

- 9 Radio waves, visible light and X-rays are all part of the electromagnetic spectrum.

Which is the correct order of increasing wavelength?

	shortest wavelength	→	longest wavelength
A	visible light	radio waves	X-rays
B	visible light	X-rays	radio waves
C	X-rays	radio waves	visible light
D	X-rays	visible light	radio waves

10 A 12V lamp uses a current of 2A.

Which is the resistance when the lamp is working correctly?

- A 6Ω B 10Ω C 14Ω D 24Ω

11 In which circuit does the ammeter read 2A?

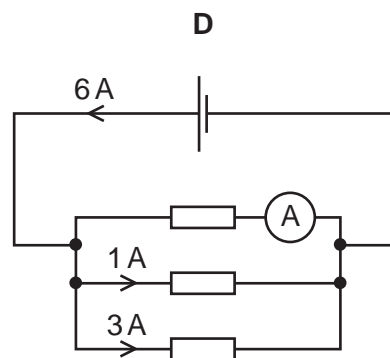
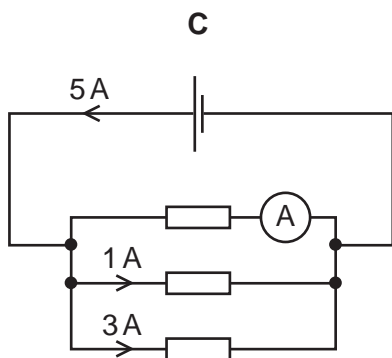
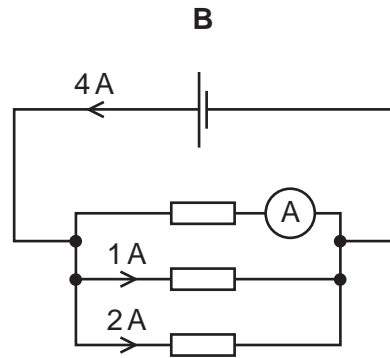
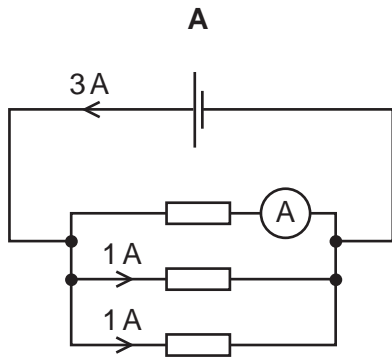

12 Electrical energy can be calculated from

- A amperes \times coulombs.
 B amperes \times ohms.
 C volts \times amperes.
 D volts \times coulombs.

- 13 An atom has a nucleus surrounded by electrons.

What are the charges on the nucleus and on the whole atom?

	charge on nucleus	charge on whole atom
A	neutral	neutral
B	neutral	positive
C	positive	neutral
D	positive	positive

- 14 A student tries to separate a mixture of ethanol and water by fractional distillation using the apparatus shown.

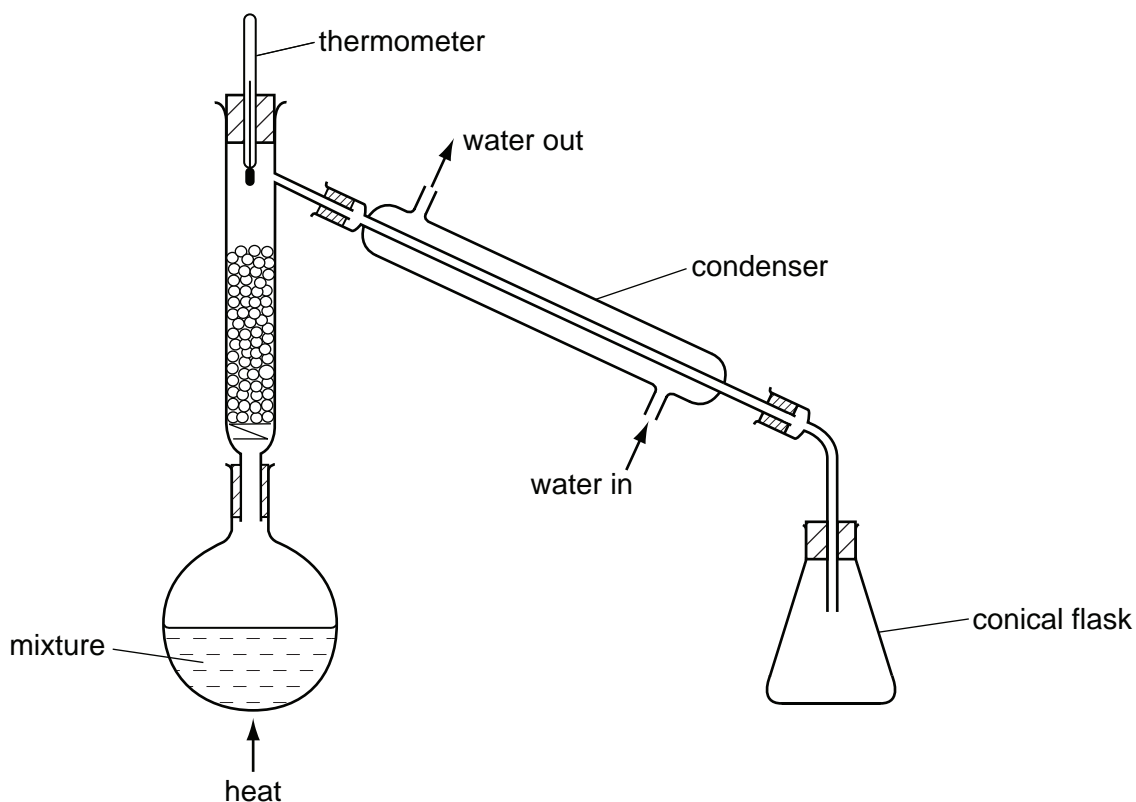

Which error has the student made?

- A** The condenser is at the wrong angle.
B The thermometer is in the wrong position.
C The top of the conical flask should be open.
D The water enters the condenser in the wrong place.
- 15 What is the nucleon number of the isotope of uranium, ${}_{92}^{235}\text{U}$?

- A** 92 **B** 143 **C** 235 **D** 327

16 Which mass of oxygen combines with 6 g of carbon to form carbon dioxide, CO₂?

- A 4g B 8g C 16g D 32g

17 The table gives some properties of four substances.

Which substance is covalently bonded?

	melting point /°C	boiling point /°C	electrical conductivity when liquid	electrical conductivity in aqueous solution
A	808	1465	✓	✓
B	-114	78	x	x
C	64	748	✓	✓
D	327	1730	✓	x

18 The equation represents the action of dilute nitric acid on copper.

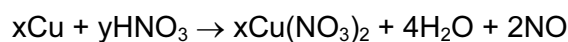

What are the values of x and y?

- A x = 1, y = 4
 B x = 1, y = 8
 C x = 3, y = 4
 D x = 3, y = 8

19 Which substance does dilute sulfuric acid **not** react with?

- A copper
 B potassium carbonate
 C sodium hydroxide
 D zinc oxide

20 Which row shows the electronic configuration of three metals?

- A 2 2,8 2,8,8
 B 2,1 2,8,1 2,8,8,1
 C 2,7 2,8,7 2,8,18,7
 D 2,8,3 2,8,4 2,8,5

21 Which statement indicates that sodium is a Group I (alkali) metal?

- A It is a good conductor of electricity.
- B It melts.
- C It burns readily in air.
- D It floats on water.

22 Q, R, S and T are four metals.

T reacts slowly with hydrochloric acid.

The oxide of Q is reduced by heating with carbon.

R reacts with steam but not with cold water.

S reacts violently with cold water.

What is the order of reactivity of the four metals, most reactive first?

- A $Q \rightarrow T \rightarrow R \rightarrow S$
- B $Q \rightarrow R \rightarrow T \rightarrow S$
- C $S \rightarrow Q \rightarrow R \rightarrow T$
- D $S \rightarrow R \rightarrow T \rightarrow Q$

23 Limestone is decomposed to lime during the production of iron in the blast furnace.

Which substance does lime react with?

- A carbon
- B haematite
- C oxygen
- D sand

24 The boiling points of some elements are given in the table.

element	boiling point/°C
nitrogen	-196
xenon	-108
oxygen	-183

A mixture of nitrogen, xenon and oxygen at -200°C is allowed to warm up to -150°C .

Which elements are still in the liquid state at -150°C ?

- A a mixture of nitrogen and oxygen
 - B a mixture of nitrogen and xenon
 - C nitrogen only
 - D xenon only
- 25 Ammonium sulfate, $(\text{NH}_4)_2\text{SO}_4$, is added to soil to provide an element that is important for plant growth.

What is this element?

- A hydrogen
 - B nitrogen
 - C oxygen
 - D sulfur
- 26 Which equation does **not** represent an addition reaction?
- A $\text{CH}_2\text{Cl}_2 + \text{Cl}_2 \rightarrow \text{CHCl}_3 + \text{HCl}$
 - B $\text{C}_2\text{H}_4 + \text{Br}_2 \rightarrow \text{C}_2\text{H}_4\text{Br}_2$
 - C $n\text{C}_2\text{H}_4 \rightarrow -(\text{CH}_2-\text{CH}_2)-_n$
 - D $\text{C}_3\text{H}_6 + \text{H}_2\text{O} \rightarrow \text{C}_3\text{H}_7\text{OH}$

27 Propene is an unsaturated hydrocarbon. Its structure is shown.

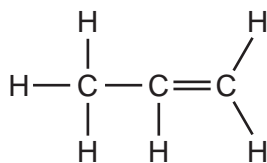

What is produced when propene reacts with bromine?

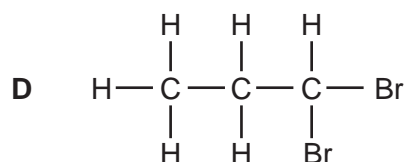
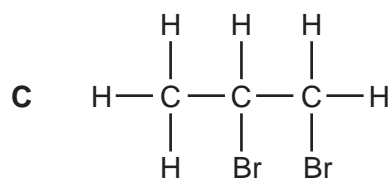
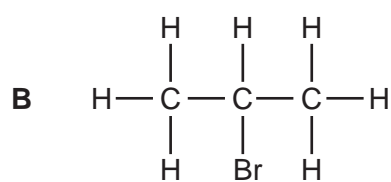
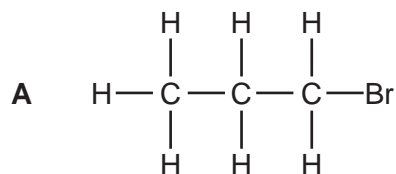

28 The diagram shows a typical plant cell after being placed into a concentrated salt solution for ten minutes.

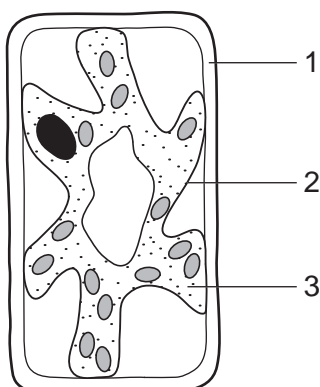

Which numbered structures are partially permeable?

- A** 1 and 2 only **B** 1 and 3 only **C** 1 only **D** 2 only

- 29 The following reaction occurs in the human alimentary canal.

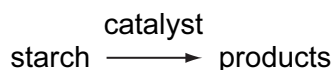

What are the catalyst and the product?

	catalyst	product
A	acid	glucose
B	alkali	energy
C	amylase	maltose
D	bile	amino acid

- 30 The graph shows the effect of different colours of light on the rate of oxygen production by green plants.

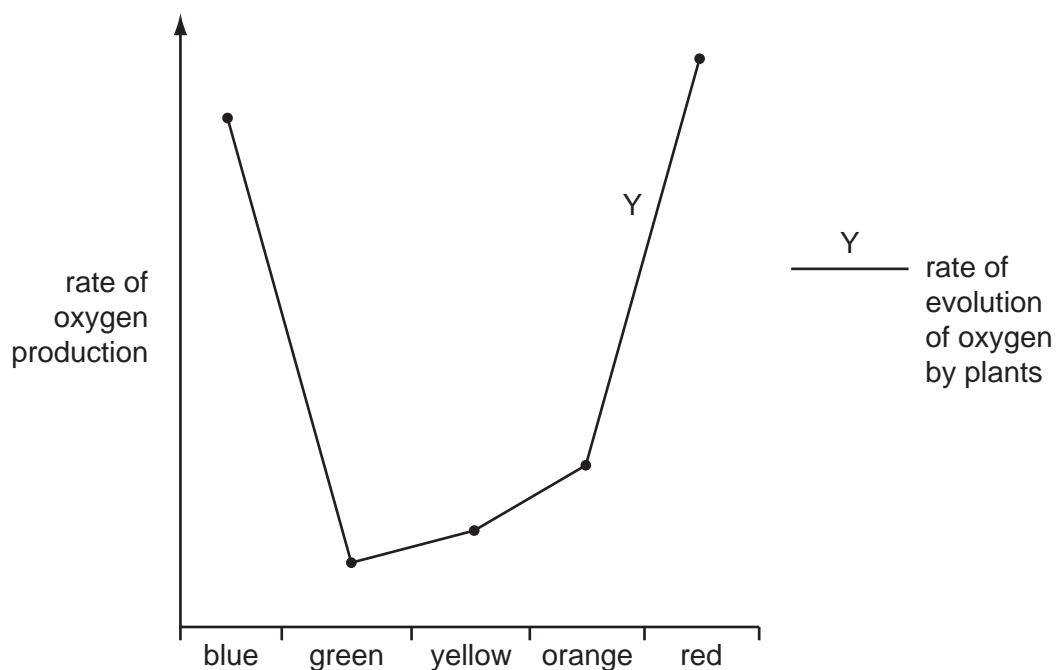

What can be deduced from the graph?

- A** Photosynthesis is least active in green light.
- B** Photosynthesis is most active in green light.
- C** Respiration is least active in green light.
- D** Respiration is most active in green light.

31 After starch is ingested, in which order do these processes occur?

- A absorption → assimilation → digestion
- B absorption → digestion → egestion
- C assimilation → digestion → absorption
- D digestion → absorption → assimilation

32 The diagram shows a human heart seen from the front.

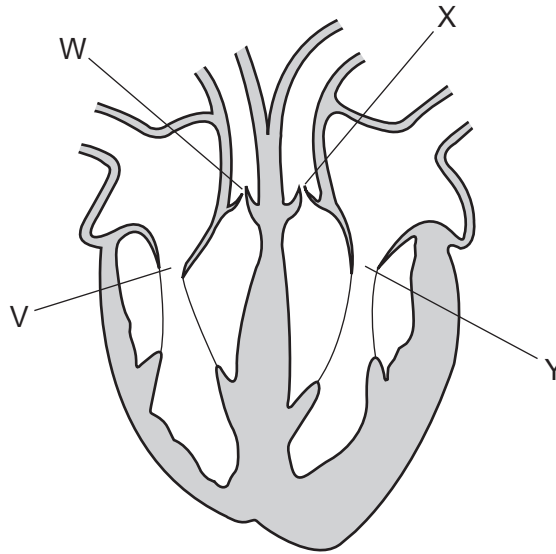

When blood is leaving the heart through the pulmonary artery and the aorta, are the labelled valves open or closed?

	V	W	X	Y
A	closed	closed	open	open
B	closed	open	open	closed
C	open	closed	closed	open
D	open	open	closed	closed

33 Which does **not** produce carbon dioxide?

- A a muscle fibre
- B a sensory neuron
- C blood
- D urine

34 Which area represents metabolic products that are removed by the lungs?

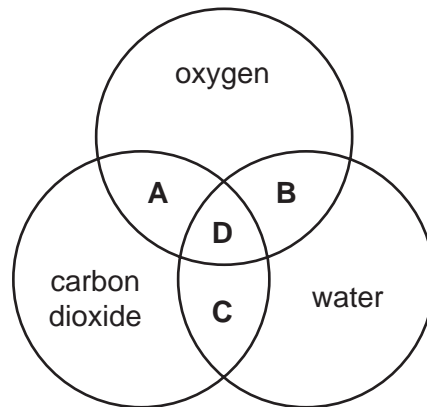

35 What happens to these structures when the eye focuses on a near object?

	ciliary muscles	suspensory ligaments
A	contract	tight
B	contract	loose
C	relax	tight
D	relax	loose

36 Which descriptions of drugs are correct?

	have side effects	are broken down by the liver
A	x	x
B	x	✓
C	✓	x
D	✓	✓

37 The diagram represents nine organisms forming a food web.

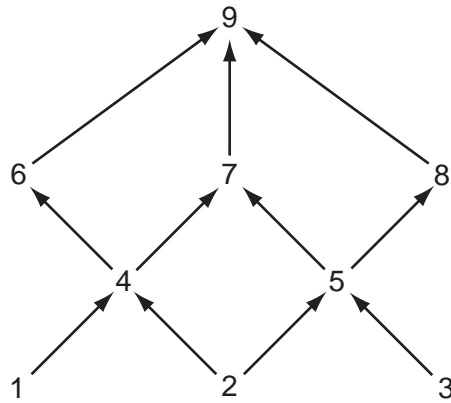

Which of the organisms is a producer and which is a carnivore?

	producer	carnivore
A	1	4
B	2	6
C	9	1
D	9	8

38 What are possible harmful effects of deforestation?

	increased carbon dioxide in atmosphere	increased oxygen in atmosphere
A	✓	✓
B	✓	x
C	x	✓
D	x	x

39 What is always true of the offspring from asexual reproduction in plants?

- A** a new variety
- B** more resistant to disease
- C** same flower shape
- D** same size

40 What is an effective treatment for syphilis?

- A antibiotics
- B anti-viral drugs
- C condoms
- D isolation from other sexual partners

DATA SHEET
The Periodic Table of the Elements

		Group																																																																																						
I	II	III	IV	V	VI	VII	0					0																																																																												
7 Li Lithium 3	9 Be Beryllium 4	1 H Hydrogen 1	11 B Boron 5	12 C Carbon 6	14 N Nitrogen 7	16 O Oxygen 8	19 F Fluorine 9	20 Ne Neon 10	27 Al Aluminium 13	28 Si Silicon 14	31 P Phosphorus 15	32 S Sulfur 16	35.5 Cl Chlorine 17	40 Ar Argon 18	45 Sc Scandium 21	48 Ti Titanium 22	51 V Vanadium 23	55 Mn Manganese 25	56 Fe Iron 26	59 Co Cobalt 27	59 Ni Nickel 28	64 Cu Copper 29	65 Zn Zinc 30	70 Ga Gallium 31	73 Ge Germanium 32	75 As Arsenic 33	79 Se Selenium 34	80 Br Bromine 35	84 Kr Krypton 36	85 Rb Rubidium 37	88 Sr Strontium 38	89 Y Yttrium 39	91 Zr Zirconium 40	93 Nb Niobium 41	101 Ru Ruthenium 44	106 Pd Palladium 46	108 Ag Silver 47	112 Cd Cadmium 48	115 In Indium 49	119 Sn Tin 50	122 Sb Antimony 51	128 Te Tellurium 52	127 I Iodine 53	131 Xe Xenon 54	133 Cs Caesium 55	137 Ba Barium 56	139 La Lanthanum 57	178 Hf Hafnium 72	181 Ta Tantalum 73	184 W Tungsten 74	190 Os Osmium 76	192 Ir Iridium 77	195 Pt Platinum 78	197 Au Gold 79	201 Hg Mercury 80	204 Tl Thallium 81	207 Pb Lead 82	209 Bi Bismuth 83	210 Po Polonium 84	210 At Astatine 85	226 Ra Radium 88	227 Ac Actinium 89	232 Th Thorium 90	238 U Uranium 92	238 Np Neptunium 93	238 Pu Plutonium 94	238 Am Americium 95	238 Cm Curium 96	238 Bk Berkelium 97	238 Cf Californium 98	238 Es Einsteinium 99	238 Fm Fermium 100	238 Md Mendelevium 101	238 No Nobelium 102	238 Lr Lawrencium 103	140 Ce Cerium 58	141 Pr Praseodymium 59	144 Nd Neodymium 60	150 Sm Samarium 62	152 Eu Europium 63	157 Gd Gadolinium 64	159 Tb Terbium 65	162 Dy Dysprosium 66	165 Ho Holmium 67	167 Er Erbium 68	169 Tm Thulium 69	173 Yb Ytterbium 70	175 Lu Lutetium 71

*58-71 Lanthanoid series
†90-103 Actinoid series

Key
a **X**
b

a = relative atomic mass
X = atomic symbol
b = proton (atomic) number

The volume of one mole of any gas is 24 dm³ at room temperature and pressure (r.t.p.).

Permission to reproduce items where third-party owned material protected by copyright is included has been sought and cleared where possible. Every reasonable effort has been made by the publisher (UCLES) to trace copyright holders, but if any items requiring clearance have unwittingly been included, the publisher will be pleased to make amends at the earliest possible opportunity.